

THE GUARRANTEE OF WINNING SOLUTIONS

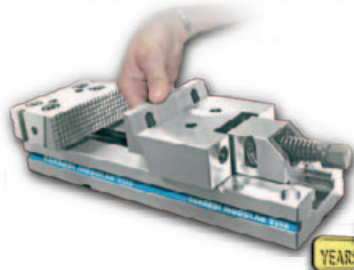

The most recent

StandardFLEX vises with quick change jaw plates

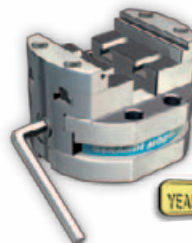

Self-centering or eccentric

MULTITASKING vises for 5 axis machining centres

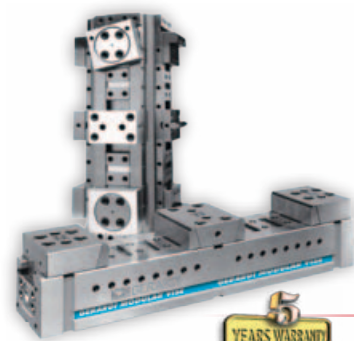

The best

FMS Vises and Vise Towers (three vises in one) for single, double and self-centering clamping

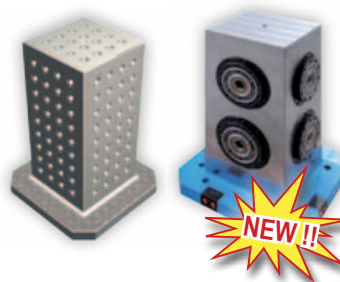

Immediate positioning and clamping

Tombstone for horizontal machining centres with Zero Point or grid type (cast iron or aluminum cast)

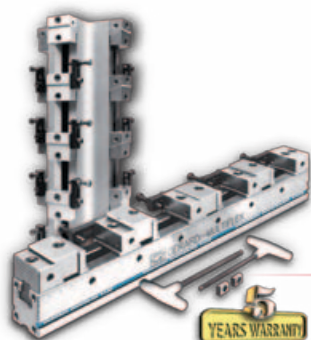

The most versatile

MULTIFLEX Vises and Vise Towers for multiclamping



Angle heads for machining centres and conventional machines



Mazak



By PARLEC

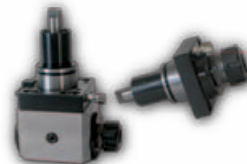

Gerardi Driven tools

- Biglia
- Daewoo
- Mori seiki
- Nakamura
- Okuma
- Takisawa
- VDI



The maximum high precision vise

Highest precision vises series **OK**. Also for checking and control, for E.D.M. machine and for milling

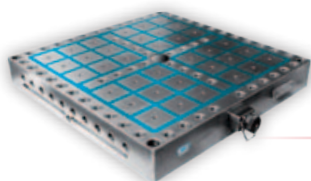

Grid magnetic plate for milling



BISON

Platform

Manual self-centering scroll chucks



Gerardi Modular System

ZERO POINT

HYDRAULIC OR PNEUMATIC

Immediate Positioning & Clamping also in vertical. Accurate, Quickest and Safe

Art. 662

HYDRAULIC

Independent mounting

Code 8.66.20000

LIST PRICE € ~~1100~~

SPECIAL PRICE € **850**

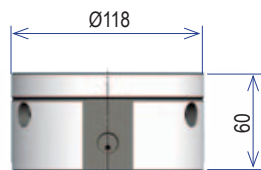

Pullstud Art. 11A

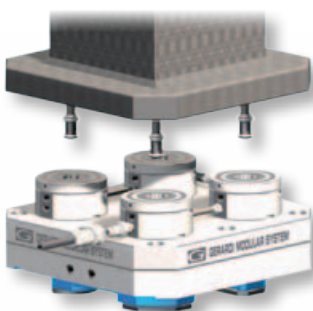

Application example

- Clamping force 25 kN
- Holding force more than 60 kN
- Hydraulic release 200 BAR
- Positioning shank with elastic collet
- Double pull-stud centering for Max rigidity
- Manually emergency release
- Water drain
- **Key ways and calibrated positioning hole**
- Weight 4,3 Kg each

Art. 664

PNEUMATIC

Mounting with flange

Code 8.66.40000

LIST PRICE € ~~900~~

SPECIAL PRICE € **750**

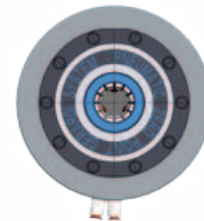
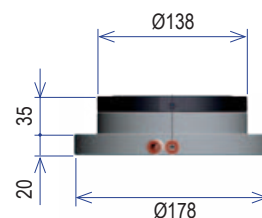

Pullstud Art. 11A

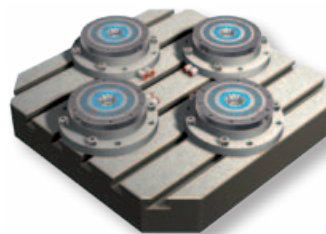

Application example

- Clamping force 10 kN
- Holding force more than 60 kN
- Pneumatic release 7 BAR
- Positioning shank with elastic collet
- Double pull-stud centering for Max rigidity
- Air cleaning
- Weight 6 Kg each

Art. 663

HYDRAULIC

Built-in mounting

Code 8.66.30000

LIST PRICE € ~~1000~~

SPECIAL PRICE € **800**

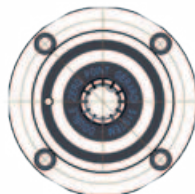
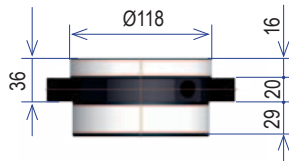

Pullstud Art. 11A



Application example

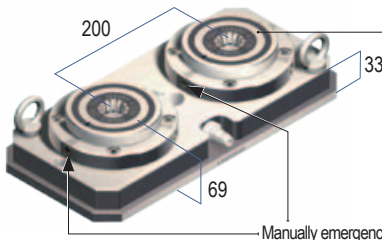

Art. 663

- Clamping force 25 kN
- Holding force more than 60 kN
- Hydraulic release 200 BAR
- Positioning shank with elastic collet
- Double pull-stud centering for Max rigidity
- Manually emergency release
- Weight 5,6 Kg each

Manually emergency chucks release

Art. 665

PNEUMATIC

Built-in mounting

Code 8.66.50000

LIST PRICE € ~~800~~

SPECIAL PRICE € **650**

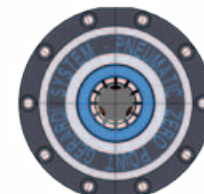
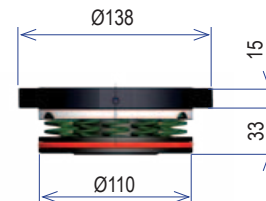

Pullstud Art. 11A



Application example

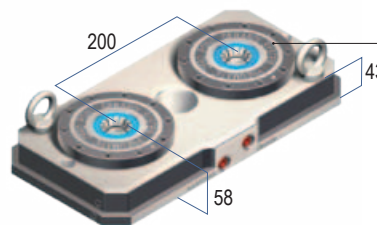

Art. 665

- Clamping force 10 kN
- Holding force more than 60 kN
- Pneumatic release 7 BAR
- Positioning shank with elastic collet
- Double pull-stud centering for Max rigidity
- Air cleaning
- Weight 2,5 Kg each

Art. 81H + 2 Art 663

Code 9.81.H2040S2

LIST PRICE € **2.026**

Art. 81P + 2 Art 665

Code 9.81.P2040S2

LIST PRICE € **1.791**

Standard equipment: N. 1 pullstud Art. 662D each single chuck - Free applications set up study

1 YEAR WARRANTY (2 YEAR WARRANTY promotionally until December 2011 !!)

All the components are built completely with high resistance steel and case hardened



GERARDI SPA

via Giovanni XXIII, 101
21015 LONATE POZZOLO (VA) Italia
Tel. +39.0331.303911 - Fax +39.0331.301534

gerardi@gerardispa.com - www.gerardi.it

Distributor: